

Forgings









Closed Die



Open Die



Rolled Rings

Certifications	     
Rolled Rings	
Stainless	19"/118" O.D.
Titanium	NA
Carbon	19"/118" O.D.
Nickel & High Temp Alloys	19"/118" O.D.
Mandrel Rings	Max Diameter 36"
Aluminum	N/A
Titanium & Ni	N/A
Stainless	9,000lbs
Carbon	9,000lbs
Bars & Shafting	OD or Square to 36,000lbs
Aluminum	NA
Titanium & Ni	NA
Stainless	36" OD x 25' L
Carbon	36" OD x 25' L
Closed Die Forging	Up to 500lbs
Bar Stock	Yes
Blocks	Yes
Discs	Up to 9,000lbs
Sleeves	Yes
In-House Heat Treat	Yes
In-House Non Destructive Testing	Yes
Rough Machine	Yes
Full Machine	Yes



Proudly Represented by SanCo Sales Inc

A Manufacturers Representative Corporation

www.SanCoSales.com 214.763.7351

Castings



Advance Bronze TALLADEGA CASTINGS & MACHINE CO.



Sand Castings

Investment Castings

Centrifugal Castings

Die Castings & Powder Metal

Permanent Mold

Domestic & Overseas

<u>Materials</u>	<u>Up To:</u>
Grey Iron	50,000lbs
Ductile Iron	20,000lbs
Aluminum	1,000lbs
Bronze/Brass	6,000lbs
Steel	4,000lbs
Titanium	800lbs
High Temp/ Exotic Alloys	800lbs

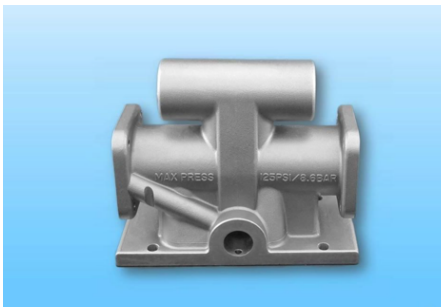
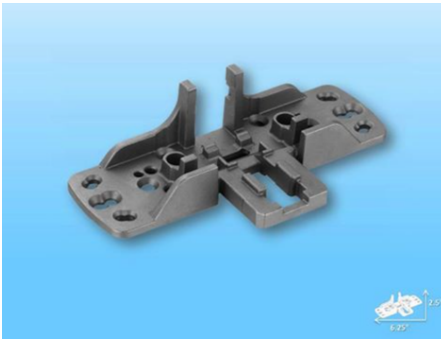
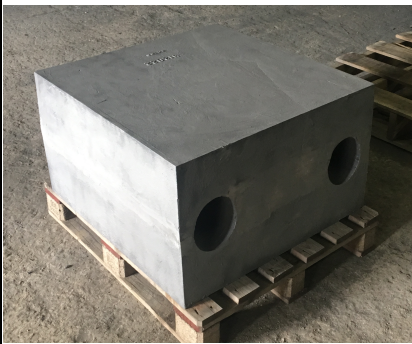

SanCo
SALES, INC.

Proudly Represented by SanCo Sales Inc

A Manufacturers Representative Corporation

www.SanCoSales.com 214.763.7351